

UNIFYING GAPPING, RIGHT-NODE RAISING, AND V°-COORDINATION

Ed Zoerner

Department of Linguistics
University of California, Irvine

1.0 The Puzzle

The phenomena known as Gapping and Right-Node Raising (RNR) have attracted much attention in the syntactic literature. The following exemplify each, respectively:

1. Robin ate beans, and Kim rice
2. Robin cooks, and Kim eats, beans

Under the standard analysis of Gapping, the second occurrence of the verb 'ate' in (1) deletes. Two different analyses have attempted to explain (2); in RNR terms (Postal (1974), among others), the identical objects of the conjoined clauses undergo ATB movement and adjoin to the right of the coordination; (3) reflects this transformation:

3. [Robin cooks t_i] and [Kim eats t_i] beans;

Others, such as Ross (1970) and Neijt (1979), claim instead that (2) demonstrates the effect of Backward Conjunction Reduction (BCR); from clausal coordination, the first occurrence of the identical object 'beans' deletes.

A fact noted by Koutsoudas (1971), however, casts doubt upon all these analyses. Koutsoudas observes that precisely those languages which permit Gapping constructions also permit RNR. Languages which lack Gapping also prohibit RNR constructions. Chinese presents such an example of the latter language type; both of the following crash:

4. *Robin da-le nanhaizi, Kim nuhaizi
hit-ASP boy girl
'Robin hit the boy, and Kim, the girl'
5. *Robin da-le, Kim ti-le nanhaizi
hit-ASP kick-ASP boy
'Robin hit, and Kim kicked, the boy'

Since these two phenomena either both occur or both do not occur in a given language, it stands to reason that they should succumb to a similar analysis. However, the standard analyses of Gapping and RNR fail to establish any such connection; Gapping depends upon deletion and RNR relies upon movement. Though both Gapping and BCR invoke a deletion transformation, Neijt (1979) shows that they do not collapse into a single rule. Among other things, Gapping targets clause-medial material and faces strict restrictions on the number of remnants it permits; RNR targets clause-final material only and can leave behind many more remnants. The following examples show this difference in the number of remnants:

6. *Robin ate beans yesterday, and Kim rice two days ago
7. Robin chopped, and Kim peeled, apples with Terry's knife in the kitchen

So present analyses do not capture the hand-in-hand relationship between Gapping and RNR very well. Koutsoudas (1971) also notes another relevant fact, largely ignored in the literature: Precisely those languages

which exhibit Gapping and RNR also license V° -coordination. English and Chinese again contrast:

8. Robin [hit and kicked] the boy
 9. *Robin da-le, ti-le nanhaizi
 hit-ASP kick-ASP boy
 'Robin hit and kicked the boy'

This fact adds to the puzzle: not only should Gapping and RNR undergo a similar analysis; the analysis should also speak to whether or not a language permits V° -coordination. Standard accounts have no way to tie together these three phenomena.

This paper proposes an analysis which unifies these three related syntactic phenomena. The analysis claims that Gapping and RNR do not result either from deletion or from optional movement, but rather from base-generated coordination of a single phrase. The argument takes the following form: first, it introduces the single phrase responsible for both Gapping- and RNR-type constructions, and shows how coordination of this phrase together with required rules of movement result in the canonical word orders such as those in (1) and (2). It then establishes the connection between Gapping, RNR and V° -coordination, and concludes with a brief analysis of complex and 'discontinuous' Gaps that demonstrates empirical advantages of the analysis.

2.0 Relation Phrases

Phrasal coordination provides conceptually the most attractive means of arriving at Gapping and RNR; the challenge stands, however, how to conform to the general requirement (as stated for example in Chomsky (1957:35)) that only like terms may coordinate. No currently recognized syntactic phrase will suffice.

Therefore, this work introduces a new phrase to serve just this end; it proposes that a language may have a Relation Phrase (RP; the motivation for the name will follow). RPs conform to X-bar theoretical principles, and take the following form (in a head-initial language):

10.

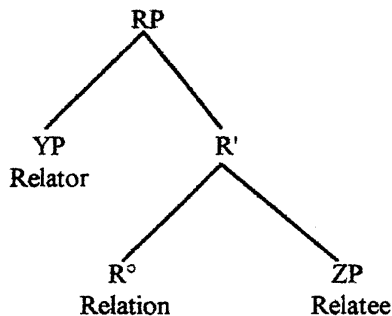

The following definitional requirement on RP sets it apart from all other XPs:

11. An RP must have an underlyingly empty position licensed by a node that immediately *c*-commands an RP-coordination.

The following diagram will clarify. In (12), an X° head mutually *c*-commands an RP-coordination, and licenses the empty R° position through a head-to head relation:¹

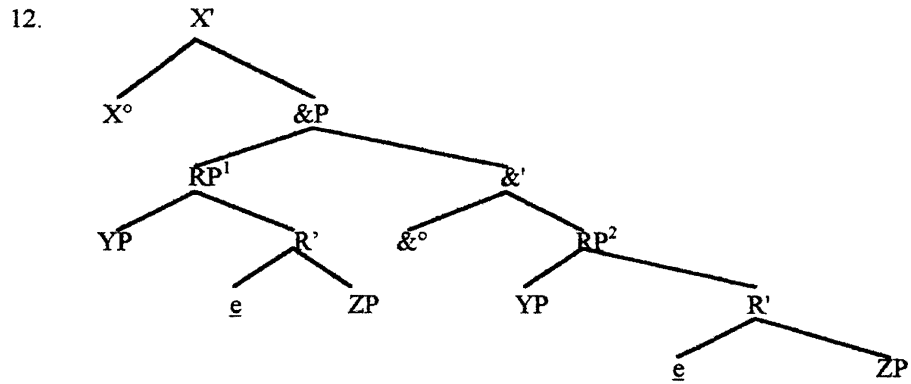

Although the YPs and ZPs above have lexical content, the R° positions do not; however, they receive licensing from the X° head and in fact inherit all of the features of the X° . The RPs in (12) will therefore have the same basic argument structure as the XPs. In a way, this concept of RPs parallels the spirit of SLASH categories in Generalized Phrase Structure Grammar theory and Categorical Grammar; these frameworks admit such constituents as S/NP, which denotes a sentence with an NP 'missing' somewhere, with the missing NP to be filled in through an appropriate structural relation with another term. This work applies such an idea within the GB framework; RPs exist as phrases with something 'missing'.

The empty elements in (12) receive licensing through a head-to-head relationship; similarly, a complement-to-complement relation can license them, as shown below:

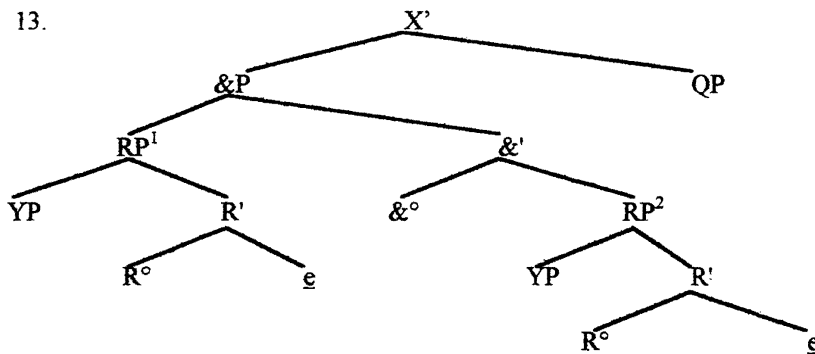

Here, the RP-coordination stands in place of an X° , and the lexically realized R° terms correspond accordingly; the argument structure of the RPs will mirror that of XP. Note that a complement QP mutually c-commands the RP-coordination; it therefore licenses the empty elements in the [Comp, R°] positions. The empty elements, under this licensing, can satisfy the selectional requirements of R° just as the QP would satisfy the selectional requirements of a noncoordinated X° .

Note that an RP will never have two empty positions, since no single node c-commanding an RP-coordination can satisfy the featural needs of two structurally different positions:

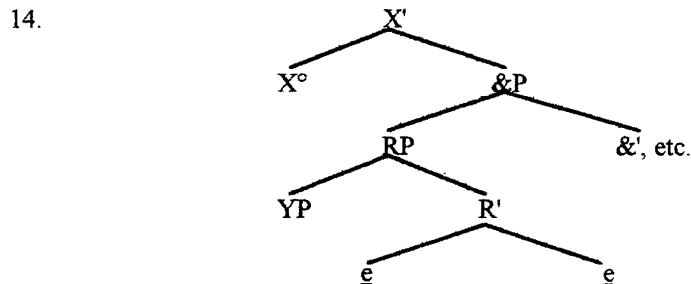

Here, for example, the X° head can license the empty R° position through the head-to-head relation discussed earlier, but cannot speak to the empty $[\text{Comp}, R^\circ]$ position. Since all empty elements must receive licensing, the form crashes.

RPs, then, have a single empty position in either R° or $[\text{Comp}, R^\circ]$.² The rest of this work will attempt to establish the following claim: when R° contains an empty element, Gapping-type constructions result; an empty $[\text{Comp}, R^\circ]$ position produces RNR-type constructions. Gapping and RNR, then, actually become mirror images of one another, inextricably linked through the presence of RP in a given language.

3.0 RPs and Gapping

Consider first how RP-coordination can produce Gapping constructions. In such forms, a lexical V° mutually c-commands an RP-coordination and licenses empty elements in the R° -slots. The relevant part of the underlying structure of (1) under this idea becomes:

15. Robin ate beans, and Kim rice

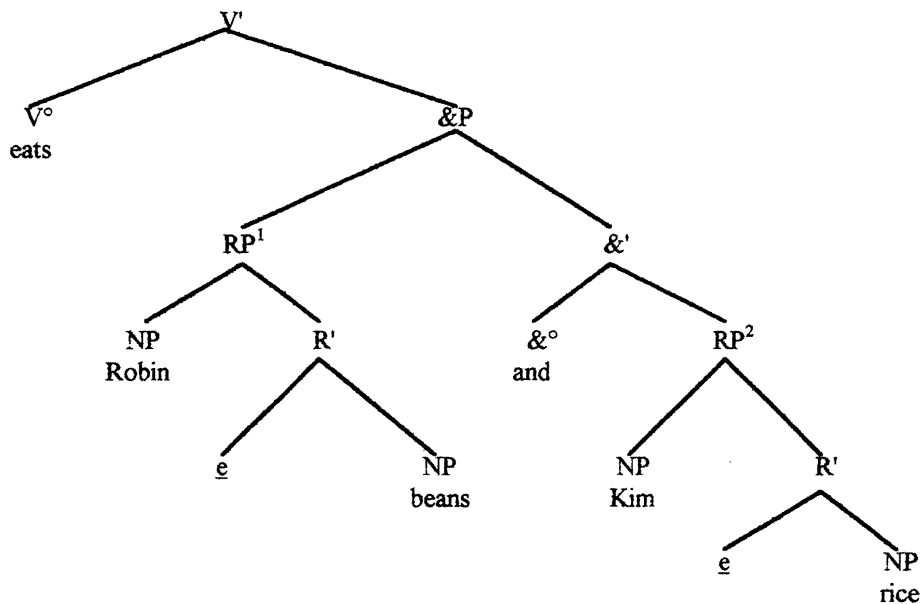

The motivation for the name Relation Phrase now becomes more evident; because the verb binds and licenses the empty elements in R° , the syntactic structure immediately reflects the semantic relations as shown:

16. ate(Robin, beans)&(Kim, rice)

The relation of eating holds between Robin and beans, and Kim and rice, respectively. Assume that the R° s, by virtue of their relationship with the lexical verb, manage to discharge all Case and theta-roles as needed.

The structure in (15) does not immediately produce the surface word order in English (though this word order does appear in Gapping constructions in Spanish, Irish and other languages). However, the correct English word order results from required movements. Because English requires Case-checking of within its AgrsP and AgroP (as described, e.g. in Chomsky (1993)), RP^1 must raise from its initial position. Though this movement does contravene the Coordinate Structure Constraint (Ross (1967)), Case requirements override this prohibition on movement. (See Zoerner (to appear) for further explanation and examples.) The result of this movement appears as:

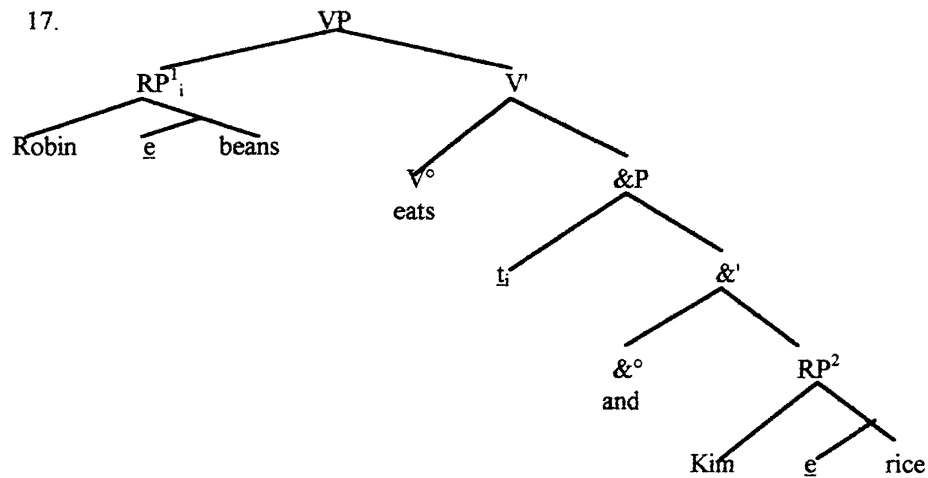

From here, the NP 'Robin' may continue raising to [Spec, AgrSP]; the NP 'beans' similarly raises to [Spec, AgroP]. The lexical verb 'eats' for its part passes through Agro° and ends in AgrS°; this yields the correct surface order of terms.³

Recall the aforementioned mystery regarding Gapping and remnants; for example, Gapping may not leave behind unlike adverbials together with unlike objects as in (6), repeated below:

18. *Robin ate beans yesterday, and Kim (ate) rice two days ago

The ungrammaticality of this form provides strong evidence for the RP-analysis and against an analysis of Gapping as a result of VP-coordination (as in, for example, Johnson (1994)). Because the RPs have only three positions--Relator, Relation and Relatee--the unlike adverbials simply have no syntactic home. RPs do not equal VPs, and do not provide an 'extra' position for adverbials as VPs might. Therefore unlike adverbials cannot surface in Gapping constructions; the restriction on the number of remnants Gapping allows falls out directly.

To sum up so far: the RP-analysis of Gapping, then, invokes neither deletion nor optional movement. Coordination of like terms--the RPs--together with required movements produce Gapping-type constructions.

4.0 RPs and RNR

Gapping results when an RP-coordination occupies [Comp, V°]. On the other hand, RNR results when an RP-coordination fills a V° position itself. The underlying structure of (2) under this idea becomes:

19. Robin cooks, and Kim eats, beans

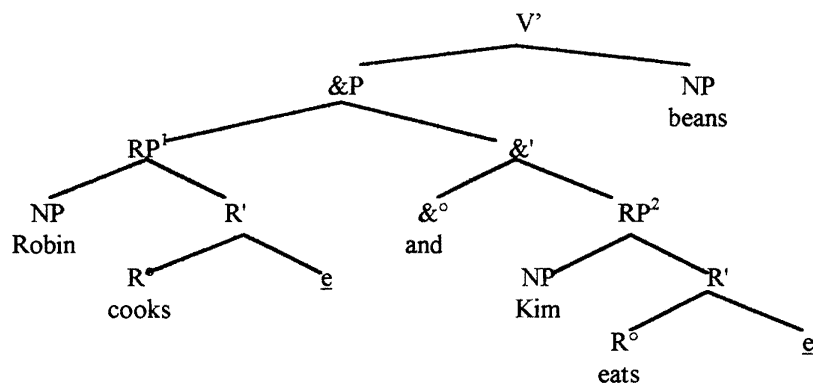

This structure generates the surface word order directly; however, exactly the same movements (this time vacuous) apply here that applied in the Gapping case. RP^1 first raises to [Spec, VP]. From there, the NP 'Robin' raises to [Spec, AgrsP]. Assume that the empty element in RP^1 , by virtue of its association with the lexical NP object 'beans', may satisfy agreement at LF; it therefore raises to [Spec, AgroP]. The verb as always raises and ends in $Agrs^o$; the correct surface order results.

Note in passing an advantage that the structure in (19) enjoys over a BCR analysis; it correctly reflects the prosodic structure of the form. BCR cannot explain the necessary intonational break between the terms 'eats' and 'beans'; under the RP-analysis this pause indicates their membership in different constituents.

The analysis can also account for the fact that RNR, unlike Gapping, may have more than one remnant. Consider the structure of (7), repeated below:

20. Robin chopped, and Kim peeled, apples with Terry's knife in the kitchen

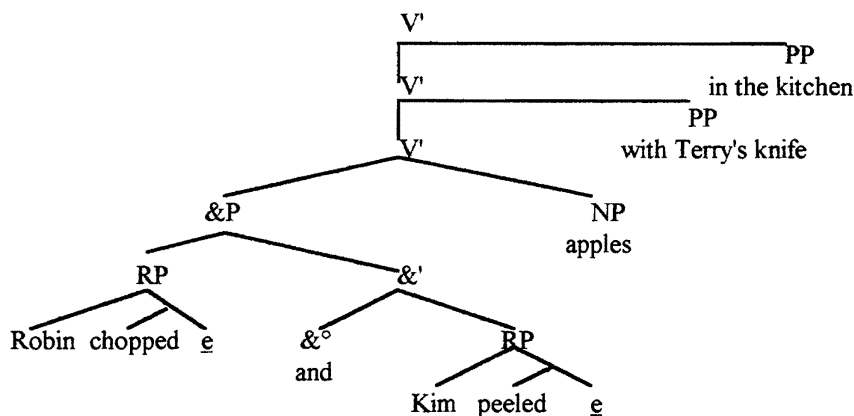

Because English permits any number of rightward PP adjuncts generally, the RNR facts fall out directly. The difference in remnants between Gapping and RNR, then, falls out as a natural consequence of the analysis and does not require any ad hoc stipulation.

To sum up: RP can have an empty element in one of two positions; one of the empty positions results in Gapping, and the other produces RNR. This neatly accounts for part of the puzzle posed at the outset; Gapping and RNR either both occur in a given language or both do not occur due to the presence or lack of RP in a language's inventory. Gapping and RNR go together as two sides of the same syntactic coin.

5.0 RPs and V^o-Coordination

Although the RP-analysis does manage to make the conceptually desirable step of unifying the phenomena of Gapping and RNR, nothing so far has addressed the question of why a language might or might not contain RP in its inventory. English, which contains RP, exhibits both Gapping and RNR; Chinese, which lacks RP, exhibits neither. But the presence or absence of RP needs a more profound explanation.

The previously noted fact that only those languages with Gapping and RNR also have V^o-coordination provides the key to this part of the puzzle and support the ideas underpinning the RP-analysis. Consider again the canonical structure for an RNR construction:

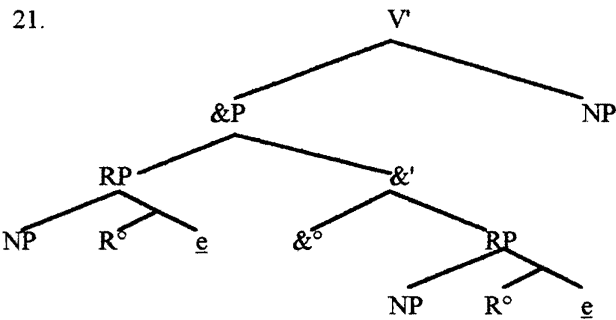

As noted earlier, the RP-coordination stands in lieu of a V° term, and in fact the R° positions contain lexical verbs. Because RNR results from a coordination in a V° position, it follows that those languages which prohibit V°-coordination even of single lexical verbs will also prohibit such RP-coordination.

A look at the canonical Gapping construction points to the same conclusion:

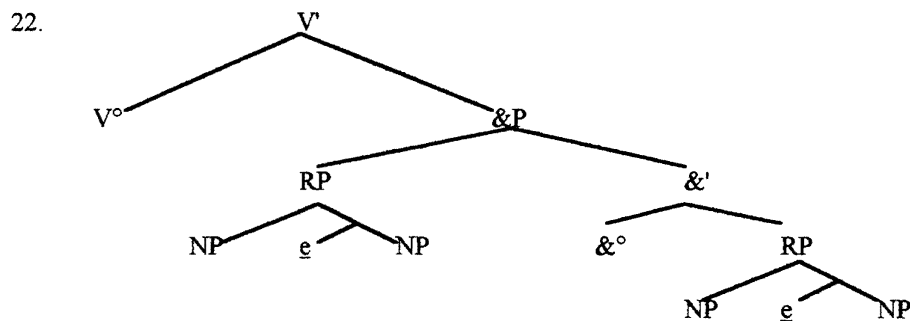

Here, the V° associates with the empty R° positions through c-command. As noted earlier, the R°s in effect become V°s by virtue of this structural relation. In a sense, then, the lexical V° does coordinate. Once again, it follows that those languages which prohibit V°-coordination generally will also prohibit Gapping, which relies crucially on this type of V°-coordination.

It turns out, then, that V°-coordination stands as a primitive. Languages either allow it or they do not, and from this it necessarily follows whether or not they will allow Gapping and RNR. The RP-analysis, then, succeeds in unifying these three phenomena in a principled way.

6.0 Further Empirical Support for the RP-Analysis

In addition to this conceptual advance, the RP-analysis also provides straightforward answers to previously unresolved empirical issues of Gapping and RNR. This section contains a brief look at two such benefits.

6.1 Directionality

Note that under a deletion account, identical verbs in English delete forward while identical objects delete backward:

23. Robin eats beans, and Kim rice
 24. Robin cooks, and Kim eats, beans

In a head-final language such as Japanese, the opposite holds; verbs delete backward and objects delete forward:

25. Robin-wa hon-o, Kim-wa shimbun-o yonda
 TOP book-ACC TOP newspaper-ACC read-PT
 'Robin read a book, and Kim a newspaper'
26. Hon-o Robin-wa katta, Kim-wa yonda
 book-ACC TOP buy-PT TOP read-PT
 'Robin bought, and Kim read, a book'

Ross (1970) proposes what amounts to a Directionality Constraint (DC) to account for the difference in verb-deletion and object deletion; the DC states that left-branching terms delete forward and right-branching terms delete backward. This DC does provide a descriptive adequacy, but nothing conceptually motivates it; there seems no a priori reason, for example, why left-branching elements should not delete backward and right-branching elements forward. The DC stands as best as a descriptive generalization.

The RP-analysis, however, does away with any need to stipulate a DC; the order of constituents in Gapping and RNR constructions falls out directly as a result of the language's head-parameter. Previous diagrams have shown how the word order in a verb-initial language such as English results. Now consider the corresponding diagrams in Japanese:

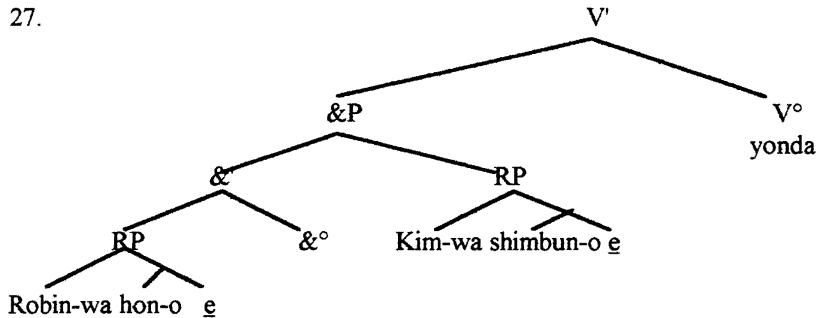

Both the &P and the RP show head-final status just as the Japanese VP does. The base-generated structure above produces the correct surface order of terms. Fukui (1993 and elsewhere) holds that Japanese may lack Agreement nodes entirely; if so, then no movement occurs and the diagram in (27) represents the end of the story. No deletion has occurred, so no need to appeal to a DC arises.

The object deletion facts fall out in the same way. Consider:

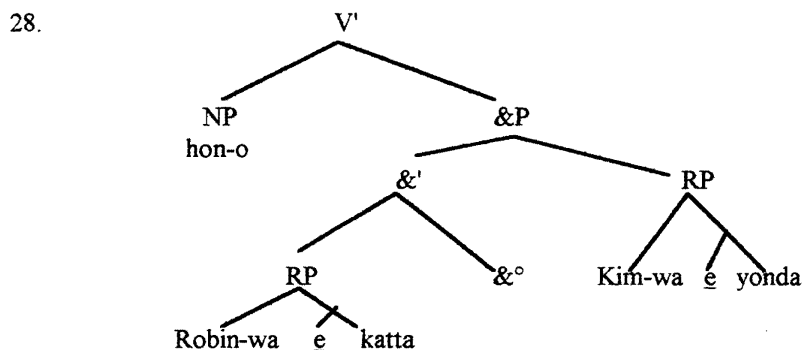

Again, the construction contains only one lexical direct object, which necessarily precedes any verb. The base-generated structure produces the correct word order. The impression of forward deletion, then, simply results from the verb-final status of Japanese.⁴ The RP-analysis supplants the DC in both head-initial and head-final languages.

6.2 V+Direct Object Gaps and 'Discontinuous' Gaps

Consider the following two grammatical Gapping examples:

29. Robin reads books in the park, and Kim at home
 30. Robin ate beans yesterday, and Kim rice

(29) shows a complex Gap of a verb and following direct object. (30) shows an apparent discontinuous Gap; the form necessarily means that Kim ate rice yesterday rather than on some other day, so both the verb and the adverbial appear to Gap. Deletion-based Gapping accounts must simply stipulate that Gapping can target a V+DO string or even nonconstituents to produce these two forms. However, these stipulations run into difficulties. If one concedes that deletion may affect a V+DO string, the (b) form should follow from the grammatical input (a) below:

31. a. Robin reads books, and Kim reads books
 b. *Robin reads books, and Kim

(31b) shows an ungrammatical case of bare argument stranding; the deletion account of Gapping needs an ad hoc stipulation to rule it out. As for (30), the concession that Gapping can apply to discontinuous strings flies in the face of the general assumption that a single transformation operates on a single constituent only.

However, given a single extra claim within the spirit of the analysis, the RP-account can show (29) and (30) as related structures. Recall the previous claim that Gapping-type constructions result when a V° immediately c-commands an RP-coordination. Grant now the following: Gapping may also result when a V' c-commands an RP-coordination. Under this idea, the underlying structure of (29) assumes the configuration:

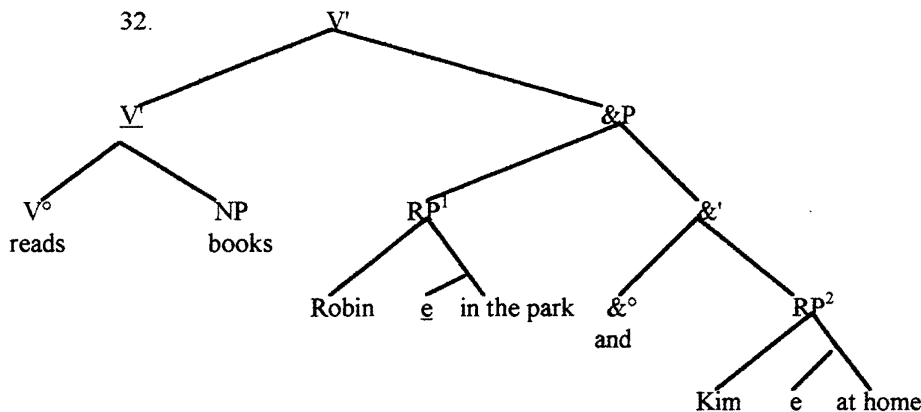

Here, the underlined V' binds the empty elements within the RPs and thus licenses them. Note that PPs rather than NPs occupy the Relatee positions in the RPs; this comes at no cost since the R°s associate with verbs and verbs permit such PP-configurations. Consider now the required movements that result in the final word order. Both AgrsP and AgroP need Case-checking of an NP. Therefore, first, RP¹ raises to [Spec, VP]. The [Spec, AgrsP] position needs an NP that bears Nominative Case (NOM). Because the NP 'Robin' has received NOM within its RP, it raises to that position and satisfies checking requirements. In a similar vein, [Spec, AgroP] needs an NP that bears Accusative Case (ACC). The PP 'in the park' and the NP 'books' stand as the two possible candidates to undergo such raising; the latter necessarily wins out, though, since unlike the PP it bears the appropriate ACC for feature-checking. Therefore, 'books' necessarily raises to [Spec, AgroP], which produces the correct word order.⁵

The apparent discontinuous Gapping case in fact results from the same basic construction. Accept with Larson (1988) that adverbials occupy the innermost complement of a V°. This means that (30) will have the following underlying structure:

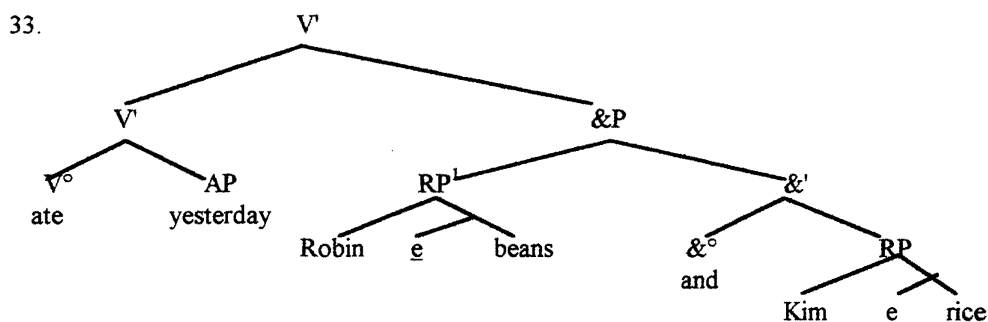

Turn now to the various movements required by the AgrPs. As always, RP^1 raises to [Spec, VP]. From here, the Relator NP 'Robin' raises to [Spec, AgrSP]. [Spec, AgrSP] also needs an NP; here, the NP 'beans' bears the appropriate ACC and raises accordingly. The adverbial 'yesterday' does not raise because it cannot meet the feature-checking needs within either AgrP. It remains in situ while the verb 'ate' raises up to AgrS $^{\circ}$; this directly produces the surface word order of (30). So both the V+Direct Object Gaps and the 'discontinuous' Gaps result from the same phenomenon of a V' c-commanding an RP-coordination; whether or not the [Comp, V $^{\circ}$] term can satisfy agreement-checking or not determines whether the Gap will surface as complex or discontinuous.

7.0 Conclusion

The introduction of RP unites the syntactic processes of Gapping and RNR, whereas previous analyses have failed to establish this vital connection. Furthermore, it does so in a way that ties them together with V $^{\circ}$ -coordination, which represents another conceptual advance. The ability of the analysis to handle more complicated cases of complex and discontinuous Gapping suggests strongly that this introduction of RPs renders empirical advantages to accompany its conceptual ones.

NOTES

My thanks go to Robert May for helpful comments and criticisms on an earlier version of this work.

1. Assume along the lines of Munn (1992) that a coordinating conjunction (&) heads its own functional phrase &P.
2. Space limitations preclude a detailed explanation of why empty elements do not surface in [Spec, RP]. Essentially, if a [Spec, XP] term mutually c-commanded an RP-coordination that stood in lieu of an X' constituent, the resulting structure would produce the same word order as straight X'-coordination, but with vacuous empty elements present. Assume that the grammar prohibits such vacuous structure.
3. Assume that Case-checking within an AgrP at LF requires lexical content in the Agr $^{\circ}$ head; hence the lexical verb rather than the associated empty element raises to that position.
4. Note that the closest NP 'Robin' can scramble over the direct object; this results in the grammatical:
 - i. Robin-wa hon-o katta, Kim-wa yonda
 TOP book-ACC bought TOP read
 'Robin bought, and Kim read, a book'
 However, in no case may such scrambling violate the head-final status of Japanese.
5. Bare argument stranding constructions would require empty elements in both the empty R $^{\circ}$ and [Comp, R $^{\circ}$] positions (as in (14)); the present analysis therefore rules them out at no extra theoretical cost.

REFERENCES

- Bierwisch, Martin and K.E. Heidolph, eds. (1970) *Progress in Linguistics: A Collection of Papers*. The Hague: Mouton.
- Chomsky, Noam (1993) A Minimalist Program for Linguistic Theory. In Hale and Keyser, eds., pp. 1-52.
- Chomsky, Noam (1957) *The Logical Structure of Linguistic Theory*. Reprinted 1975. Chicago: University of Chicago Press.
- Fukui, Naoki (1993) *Theory of Projection in Syntax*. UC Irvine manuscript.
- Gazdar, Gerald (1981) Unbounded Dependencies and Coordinate Structure. *Linguistic Inquiry* 12, 155-84.
- Hale, Ken and Samuel Keyser, eds. (1993) *The View from Building 20: Essays in Linguistics in Honor of Sylvain Bromberger*. Cambridge MA: MIT Press.
- Johnson, Kyle (1994) Bridging the Gap. UMass Amherst manuscript.
- Koutsoudas, Andreas (1971) Gapping, Coordinate Reduction and Coordinate Deletion. *Foundations of Language* 7, 337-86.
- Larson, Richard (1988) On the Double Object Construction. *Linguistic Inquiry* 19, 335-91.
- Munn, Alan (1992) A Null Operator Analysis of ATB Gaps. *The Linguistic Review* 9, 1-26.
- Neijt, Anneke (1979) *Gapping: A Contribution to Sentence Grammar*. Dordrecht: Foris.
- van Oirsouw, Robert (1987) *The Syntax of Coordination*. New York: Croom Helm.
- Ross, John R. (1970) Gapping and the Order of Constituents. In Bierwisch and Heidolph, eds., pp. 249-59.
- Steedman, Mark (1990) Gapping as Constituent Coordination. *Linguistics and Philosophy* 13, 207-63.
- Zoerner, Ed (to appear) The Case of &'-adjunction to VP. In *The Proceedings of the Conference on Configurations*. Ithaca: Cornell Cascadilla Press.