

THE TONE STRUCTURE OF CHINESE REGULATED VERSE¹

Ping Xue

Department of Linguistics
University of Victoria

1. INTRODUCTION

The tone patterns of Chinese regulated verse have long remained as one of the most obscure parts of Chinese versification. It was once believed that no apparent specific structure was obtainable in these traditional patterns except a tendency to group syllables in contrasting pairs. The appearance of metrical phonology (Lieberman and Prince, 1977) stimulated interest in reexamining these tone patterns. Since then, quite a few analyses have been proposed, resulting in recognizing that the phonological representation of the tone patterns in Chinese regulated verse lines has a hierarchically organized structure. This is definitely a great advance in the studies of Chinese versification. However, these analyses did not adequately achieve the goal of offering a unified account of the hierarchy. It seems that the problems or difficulties they suffered from, quite parallel to what was once faced with in the analysis of English stress patterns, result largely from the inadequate exploitation of certain important properties of metrical structure, such as the internal structures of prosodic constituents and relevant domains of rules. As a result, the underlying phonological hierarchy of Chinese regulated verse has not been fully explicated.

This paper will recapitulate the treatments and arguments presented in previous analyses, especially in Chen (1979) and Yip (1980). It will be shown that half-lines as well as metrical feet are independent prosodic categories in Chinese regulated verse. Feet, but not half-lines, are employed in the previous analyses. This paper argues that specifying the independent status of half-lines will not only allow for a unified account of the tone structure, but also provide detailed justification for the claim that the canonical tone patterns in Chinese regulated verse are hierarchically structured.

2. CHINESE REGULATED VERSE AND PREVIOUS ANALYSES

Chinese regulated verse has a highly formalized character, a tradition of more than one thousand years. It is called regulated verse because it requires a poem to have a fixed number of lines, a fixed number of syllables in each line, and, above all, a fixed tone pattern throughout the poem. A poem normally consists of one octet of eight lines, which is subdivided into two quatrains of identical metrical structure. A verse line can either be heptasyllabic or pentasyllabic as long as all the lines of a poem have the same length. The beginning line alternates between two underlying patterns, resulting in two different types, A and B. In poetry, the four Chinese tones are divided into two general

tone categories. Roughly speaking, the one with a steady-state pitch is referred to as "even" tone, while all the others, i.e. those rising, falling and falling-rising contour, are referred to as "oblique" tone. Assuming E and O stand for the even and oblique tones respectively, the basic canonical tone patterns are as in (1):²

(1)	Heptasyllabic A	Pentasyllabic A
	1. O O E E E O O	1. E E E O O
	2. E E O O O E E	2. O O O E E
	3. E E O O E E O	3. O O E E O
	4. O O E E O O E	4. E E O O E
	5. O O E E E O O	5. E E E O O
	6. E E O O O E E	6. O O O E E
	7. E E O O E E O	7. O O E E O
	8. O O E E O O E	8. E E O O E
	Heptasyllabic B	Pentasyllabic B
	1. E E O O E E O	1. O O E E O
	2. O O E E O O E	2. E E O O E
	3. O O E E E O O	3. E E E O O
	4. E E O O O E E	4. O O O E E
	5. E E O O E E O	5. O O E E O
	6. O O E E O O E	6. E E O O E
	7. O O E E E O O	7. E E E O O
	8. E E O O O E E	8. O O O E E

We can see that there is a regular tone alternation within a line, and contrast and repetition of tone-sequences in the whole poem. Since type A and type B verses have the same possible verse lines (they are different only in terms of the ordering of the lines) and the last four lines are identical with the first four lines in an octet, there are in fact only four verse lines permitted for heptasyllabic and pentasyllabic verses respectively, although the number of the possible combinations of E and O in a seven-syllable or five-syllable line is much larger.³

In the light of Liberman and Prince (1977), Chen (1979) proposed an analysis, first demonstrating that these tone patterns could be best accounted for in terms of a binary hierarchy. The rules Chen proposed include the following:

(2) a. Hierarchical Structure

A metrical line is hierarchically structured with exclusively binary branchings. The second half-line can be either right-(R) or left-branching (L).

b. Tone Assignment

Opposite tones (T and T') are assigned to sister constituents down to the level of the metrical foot in this fashion:

$$T \text{ ----} > T' \quad T ; \quad T' \text{ ----} > T \quad T'$$

c. Tone Specification

T may assume the value of either E or O, and T' is opposite to T, subject to the Tonotactic Condition.

d. Tonotactic Condition

If Tone Assignment produces four consecutive syllables carrying an identical tone, the tones of the second half-line undergo alpha-switching (E to O, and vice versa).

The structures in (3) are examples of the derivation for heptasyllabic lines.⁴

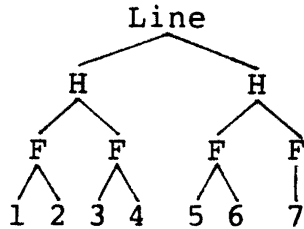
(3)a. Hierarchical Structure
Left-branching

Right-branching

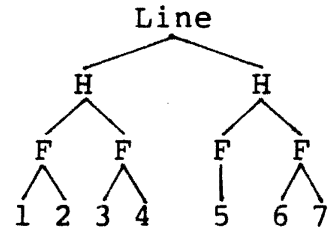
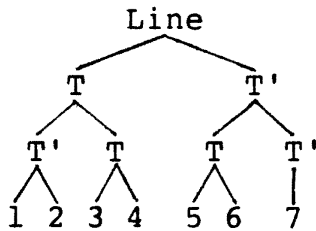
b. Tone Assignment
Left-branching

Right-branching

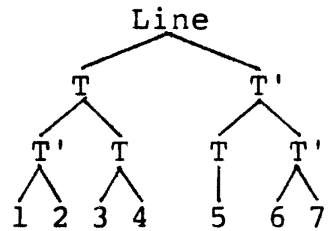
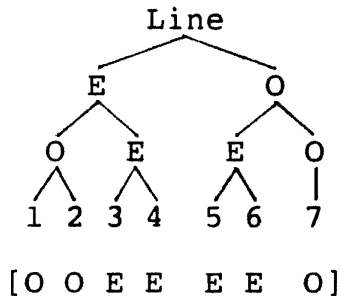
c. Tone Specification
Left-branching

Right-branching

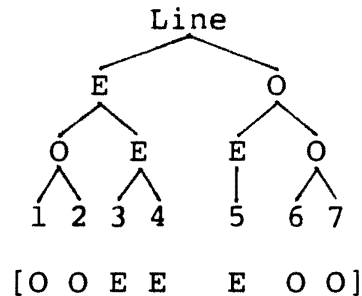

In the structures, H stands for a half-line and F stands for a metrical foot. As shown in (3), although the right-branching structures are suitable, all the left-branching structures are not well-formed structures after the application of the Tone Specification since four identical tones are adjacent. These structures are actually intermediate outputs, which need to be readjusted by the Tonotactic Condition, as shown in (4).

(4) Tonotactic Condition
left-branching

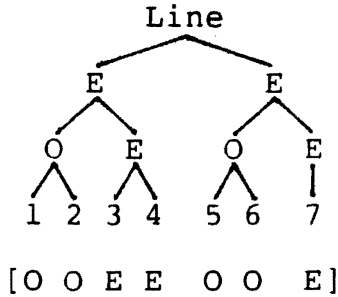

To reject Chen's treatment in terms of the Tonotactic Condition and to relate tone assignment directly to the metrical tree, Yip (1980) suggested the following two rules to treat heptasyllabic and pentasyllabic verse lines respectively. According to Yip, heptasyllabic lines are labelled by Labelling Convention 1, while pentasyllabic lines are labelled by Labelling Convention 2.

(5) a. Labelling Convention 1

In a pair of sister nodes $N_1 N_2$, N_1 is labelled T if and only if it branches.

Heptasyllabic
Left-branching

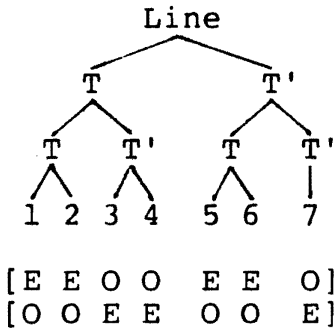

Right-branching

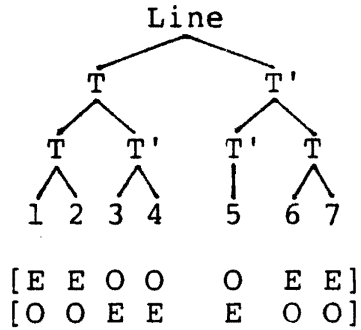

(T = E)
(T = O)

b. Labelling Convention 2

In a pair of sister nodes $N_1 N_2$, N_2 is labelled T if and only if it branches.

Pentasyllabic
Left-branching

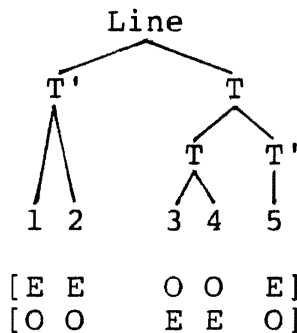

Right-branching

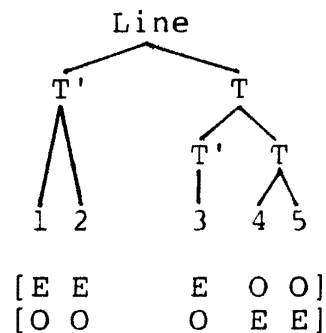

To compare with Chen's analysis, Yip's analysis is a much simpler and more elegant treatment since the distinction between branching and nonbranching nodes has been found to be a relevant factor in node labelling and, therefore, in tone assignment. Regardless, Yip's analysis is still not an optimal treatment, one which should capture all the generalizations. The following sections will illustrate that both heptasyllabic and pentasyllabic verse lines are generated by only one universal convention rather than by two, and that this analysis accounts for some generalizations which have not been adequately discussed previously.

3. FURTHER GENERALIZATIONS

This paper claims that there is only one labelling rule for both heptasyllabic and pentasyllabic verse lines. The first argument concerns intuition, which rejects the treatment that heptasyllabic and pentasyllabic lines are derived independently. Intuition suggests that heptasyllabic lines have a "heavy" beginning part, while pentasyllabic lines have a "light" one. It appears that even though two respective rules did exist, they would be two quite parallel rules slightly modified from one basic rule, not the two "reverse" to each other. Those familiar with Chinese regulated verse have intuition about whether or not a particular verse line is metrical regardless of their poetic training.

The insight provided by the standard traditional analysis clearly can serve as a second argument. Wang (1957) in his influential work on Chinese versification states that both heptasyllabic and pentasyllabic lines can be derived from two basic schemes, which could be depicted as follows:

(8) Left-branching

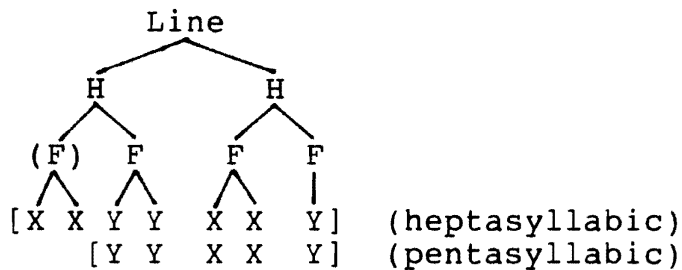

Right-branching

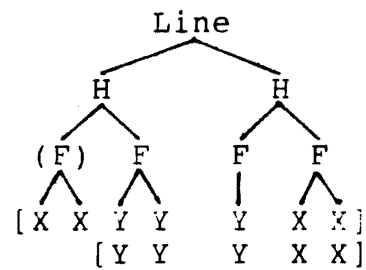

X and Y are distinct dummy variables. In terms of tone specification, X and Y can assume either E or O as their values, but if X assumes the value of E, Y must assume the value of O, and vice versa. Notice that the tone value of the variables X and Y may vary as long as one is opposite to the other, but the parallel relation between heptasyllabic and pentasyllabic lines holds constant as shown in the schemes. Obviously, alternating between the two values, only four possible lines are to be generated for heptasyllabic and pentasyllabic verses respectively. This is just what are permitted.

Given these discussions above, generalizations apparently include at least the following:

- (9) a. Syllables within a foot have the same tone.
- b. Two sister feet, namely, the feet within the same half-line, must have opposite tones.
- c. The two adjacent non-sister feet, that is, the last foot in the first half-line and the first foot in the second half-line, must have opposite tones if and only if the first foot in the second half-line is disyllabic, therefore branching; otherwise, they have the same tone.
- d. The tone pattern of a heptasyllabic line is exactly like that of a corresponding pentasyllabic line except that a heptasyllabic line has one more foot prefixed in the first half-line.

It should be noted that neither Chen's nor Yip's treatment captures all these generalizations. Chen mistakenly ignored the fact, as described in (9c), that the tone value of the first foot in the second half-line alternates crucially according to whether it is branching or nonbranching. As Yip (1980) notes, the problem arises because Chen's tone assignment rules assign the same tone to the two different underlying structures, left-branching and right-branching (i.e. left-nonbranching). Further, although a desired tone pattern is obtained after the application of the Tonotactic Condition, the structure is not well-formed at all, where sister nodes, namely, half-lines, have the same value (see the structure in (4) above). As is well-known, the essence of metrical phonology is relative "prominence", and the universal principle of metrical phonology independently disallows structures like:

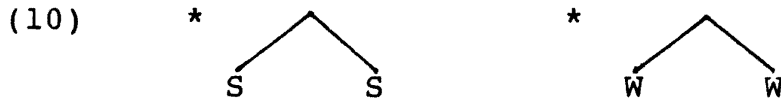

Yip's analysis relates the tone alternations directly to metrical structures. But it is not correct that heptasyllabic and pentasyllabic verse lines are generated respectively by two separate rules. Obviously, Yip fails to capture the generalization between heptasyllabic and pentasyllabic verse lines, described in (9d). Any analysis which has systematic exceptions or misses systematic phenomena with respect to the object in question cannot be an optimal treatment.

4. A UNIFIED ACCOUNT OF THE TONE STRUCTURE

Recall the generalizations described in (9) above. Here, one could see that item (a) is trivial. It can be easily handled by assuming that tone is assigned to the foot and each syllable inherits the tone from the foot (see Chen's and Yip's discussions). Item (b) is trivial, as well, since what is required is no more than distinguishing one node from the other. In terms of tree geometry, a number of labelling rules are logically possible. Again, the universal metrical theory can simply predict well-formed rules and does not allow any relevant structures in which sister nodes have the same value, such as:



Thus, the question, here, is how items (c) and (d) can be uniformly treated, i.e. the relation between the two adjacent non-sister feet and the relation between heptasyllabic and pentasyllabic lines. As noted, on the one hand, heptasyllabic lines and pentasyllabic lines are distinguished in the first half-line, depending on whether it has two feet or only one. On the other hand, the relation between half-lines is ultimately realized in the two adjacent non-sister feet in terms of tone, crucially according to whether the first foot of the second half-line is disyllabic or monosyllabic. These facts are important. They indicate that at both the half-line and foot levels, the left-hand node is essential and active. Notice that for heptasyllabic verse lines, since the two feet of the first half-line are geometrically symmetrical, theoretically speaking, either a left-oriented or a right-oriented labelling rule will have the same effect in the sense of marking the two nodes with distinct labels and it really doesn't matter which node is considered to be essential and active. For pentasyllabic verse lines, any labelling rule has no effect at all since it is irrelevant in this half-line (having only one foot). Given these facts, this paper proposes that the rule for both heptasyllabic and pentasyllabic verse lines is the following:

(12) Labelling Rule

In a pair of sister nodes $[N_1, N_2]$, N_1 is labelled N' iff it branches, otherwise, N_2 is labelled N' .

In the rule, N_1 and N_2 always have labels opposite to each other. This labeling rule, in effect, is exactly like Yip's Labelling Convention 1. The difference is that the analysis being proposed uses this single labelling rule to generate both heptasyllabic and pentasyllabic verse lines.⁵ Further, this analysis stipulates that in the rule the sister nodes N_1 and N_2 refer to two adjacent nodes at the same prosodic level, such as the foot level or half-line level. In other words, the labelling rule is strictly level-sensitive and the foot and half-line are independent prosodic categories in the present analysis. This idea could easily be formulated by specifying: $Tn_1 = Tn_2$, where Tn denotes the prosodic type of a particular node, namely a foot or half-line in the present case. Now consider actual derivations as in (13).

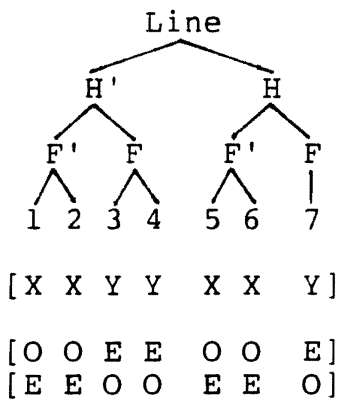
(13) a. Heptasyllabic
Left-branching

Right-branching

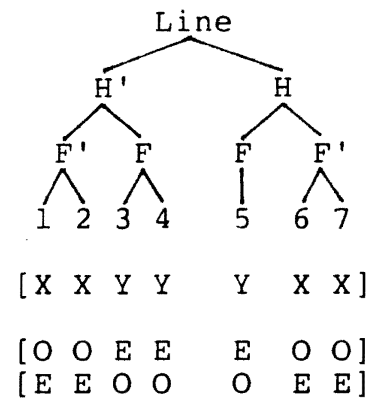
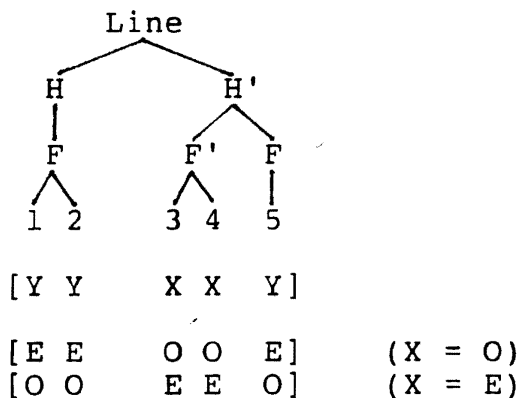
b. Pentasyllabic
Left-branching

Right-branching

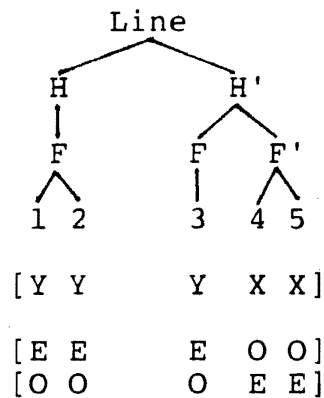

For pentasyllabic verse, the foot in the first half-line (being monosyllabic) is not labelled by the Labelling Rule, which is irrelevant here, and the foot simply inherits the label of its mother. As the variables are specified, alternating between E and O, only four possible lines are to be generated for heptasyllabic and pentasyllabic verses respectively. The labelling rule correctly generates all and only those permitted lines.⁶

Notice that for Chinese regulated verse, it is crucial to specify not only the foot but also half-line with independent status. The foot as an independent category is obvious since the tone is directly associated with the foot rather than the syllable. Downer and Graham (1963) propose an analysis, associating tones with syllables, in which they must treat the first four syllables and the other three syllables differently. Then, two questions arised and remained unexplained why odd-numbered syllables 1 and 3 always share the tones of their immediately succeeding syllables, whereas syllables 5 and 7, also odd-numbered, do not, and why syllables 1 and 2 always carry an opposite tone to that of syllables 3 and 4, whereas for the last three syllables the distinct line for the two opposite groups can be either between positions 5 and 6 or between positions 6 and 7. Dower and Graham apparently missed relevant generalizations (See Chen, 1979; and Graham, 1980 for further discussion). Actually, the notion of distinct groups has implied the notion of a super-unit bearing the tone, i.e. the metrical foot. If one says that it is the foot and not the syllable that constitutes the tone-bearing unit, the situation for the first question immediately becomes transparent: the syllables in the same foot must have the same tone.

Assuming half-lines as independent categories may appear odd and farfetched at first sight. But with a little more observation, it becomes apparent that this is a correct assumption. As mentioned, the relation between two adjacent feet is not always the same. The first and second feet always have opposite tones and so do the third and fourth feet, but this is not true of the second and third feet. They carry the same tone if the third foot is monosyllabic, otherwise, they have opposite tones. Remember that the third and fourth feet must have opposite tones even though one of them is a monosyllabic foot. This indicates that there are two kinds of adjacent relations in terms of feet in a verse line. One is obviously stricter than the other. Given a hierarchical representation, the generalization, therefore the answer to the second question above, becomes apparent that the two sister feet within a half-line always have opposite tones, while the two adjacent feet across half-lines do not. Since the relation between sisters is "more local," it will certainly be constrained by a stricter condition. Clearly half-lines are units with intrinsic content.

Wang's (1957) analysis, though not hierarchical, has in effect already suggested the independent status of half-lines. Wang shows that for heptasyllabic and pentasyllabic lines, there are four basic syllables, which are divided into two groups, distinct to each other in terms of tone. Relevant rules, such as adding syllables, further apply within each groups, namely half-lines Wang's idea is interesting because it indicates that half-lines are potentially distinct in terms of tone although the tone is not directly assigned to them. This just reflects the idea of labelling. In the present case, labels are not symbols of tones, but the phonological features which are potentially related to tones and may only be associated with tones at a particular level, i.e. the foot level in the present case. Most unfortunately, Chen simply dismissed Wang as descriptive and linear without paying much attention.

Downer and Graham (1963) offer a similar suggestion. As mentioned before, Downer and Graham treat the first four syllables and the other three syllables differently. This amounts to saying that they are domains for different rules respectively. A verse line is in effect divided into two parts, namely half-lines, distinct to each other. Downer and Graham's and Wang's analyses are important because they provide independent evidence for the existence of half-lines as prosodic categories.

Given half-lines as independent categories, the relationship between heptasyllabic and pentasyllabic lines is, apparently, that of branching vs nonbranching in terms of the first half-line. As a matter of fact, the tone value of the first foot in pentasyllabic lines is always that of the second foot in heptasyllabic lines (opposite to a branching node). This is just what the present analysis predicts.

The notion of prosodic categories is not new and has been widely accepted in the literature concerning various languages. Selkirk (1980) discusses the role of prosodic categories and indicates that English stress makes a special appeal to the syllable and foot and their internal structures. Kiparsky (1979) has a similar discussion, arguing that in English phonology the foot is independently motivated because phonological processes are actually bounded by it; therefore phonological rules make crucial use of the foot as relevant domain. Hayes (1981) presents examples from other languages, supporting the same argument. For the theory of the syllable and its relation to metrical phonology, see McCarthy (1979), Hayes (1981), and Selkirk (1982).

The assumption of level-sensitivity of rules is quite common too. Liberman and Prince (1977) employ the notion of prosodic level. Although the Word Rule and the Compound Rule in English phonology can be reduced to one general rule LCPR, word-internal structure does not count as branching when LCPR applies above the word level. Thus, both "labor union" and "Labor Day" get the compound stress on the first syllable, even though "union" branches at the foot level, contrasting with "day" which is non-branching.

Finally, another issue in the literature should be mentioned, which may also lend itself to the present analysis. The major suspicion against a hierarchical treatment of the tone structure is that hierarchical models seem to be complicated and counterintuitive. Lorentz (1980) argues that since Chinese regulated verse has been so popular in China, the rules governing the tone patterns should be easy to learn. Instead of joining the issue whether the rules are universal principle or "learned constructs," it must be pointed out that Chen's Tone Assignment with Tonotactic Condition and Yip's "reverse" rules did make the situation complicated. No wonder people complain that it is hard to see how poets construct a non-metrical structure first and then fix it up by a special condition. It is also hard to see how poets construct two quite parallel patterns with two mutually "reverse" rules. Contrasting to these treatments, the present analysis is apparently not only general but quite intuitive as well. The notion of branching vs nonbranching is simply another way expressing the intuitive idea of being "heavy" or "light" (disyllable foot vs monosyllable foot for example or in a larger unit).

5. CONCLUSION

The canonical tone patterns of Chinese regulated verse have a hierarchical structure. It is hierarchical because the syllables are grouped in terms of the feet which in turn are organized in terms of the half-lines, submitting to the relevant tone conditions as shown before. As a result, the relation between any two contiguous feet in a line as well as the relation between any two contiguous syllables is not simply a matter of linear adjacency. As we have seen, it is either the relation between two sister feet within a half-line or the relation between two non-sister feet across half-lines.

Thus, half-lines are essential prosodic categories in the tone structure of Chinese regulated verse. The traditional analyses Wang (1957) and Downer and Graham (1963) provide independent support for recognizing their existence. Neither Chen nor Yip captured the insight from Wang and Downer and Graham, or fully realized the essentiality of specifying the half-lines with independent status, although they virtually foreshadowed the notion half-line. As a consequence, they failed to represent the tone structure in a satisfactory way.

In the present analysis, by contrast, the half-lines play a crucial role. This is crucial because it not only permits a straightforward representation of the tone structure but also provides necessary and adequate justification for the claim that there is a phonological hierarchy. The logic is quite simple: the claim does not truly stand until the independent status of the half-line as well as the foot is fully recognized.

NOTES

- 1 I wish to thank Dawn Bates and WPLC editors for their helpful comments and suggestions.
- 2 Some deviation is tolerated to certain syllable positions, but that is not the concern of this paper (cf. Chen 1979, 1980). The canonical patterns and the data can be found in most standard reference books on Chinese poetry, e.g. Wang (1957) and J. Liu (1962).
- 3 The absolute numbers of the combinations of E and O in a seven-syllable and five-syllable lines are 2^7 and 2^5 respectively.
- 4 The derivation for pentasyllabic lines is exactly in the same fashion.
- 5 Yip (1980) points out that her treatment is of particular interest because it is consistent with the proposal (Halle and Vergnaud, 1978) that metrical trees in all languages are labelled by one of universal conventions, Labelling Convention 1, or its mirror image Labelling Convention 2. But note that the present treatment is perfectly consistent with the proposal.
- 6 For ordering the lines into actual verse pattern, see Chen's (1979) discussion.

REFERENCES

- Chen M. Y. (1979). Metrical Structure: Evidence from Chinese Poetry. Linguistic Inquiry 10, 371-420.
- Chen M. Y. (1980). The Primacy of Rhythm in Verse: A Linguistic Perspective. Journal of Chinese Linguistics 8, 15-41.
- Downer, G. B. and A. C. Graham. (1963). Tone Patterns in Chinese Poetry. Bulletin of the School of Oriental and African Studies 26.
- Graham, A. C. (1980). Structure and License in Chinese Regulated Verse. Journal of Chinese Linguistics 8, 42-58.
- Hayes, B. (1981). A Metrical Theory of Stress Rules. Unpublished MIT doctoral dissertation, reproduced by the Indiana University Linguistics Club.
- Halle, M. and J-R. Vergnaud. (1978). Metrical Structure in Phonology. Unpublished MS, MIT.
- Kiparsky, P. (1979). Metrical Structure Assignment is Cyclic. Linguistic Inquiry 10, 421-441.
- Liberman, M. and A. Prince. (1977). On Stress and Linguistic Rhythm. Linguistic Inquiry 8, 249-336.
- Liu, J. (1962). The Art of Chinese Poetry. London: Routledge and Kegan Paul Ltd.
- Lorentz, Ove. (1980). The Conflicting Tone Patterns of Chinese Regulated Verse. Journal of Chinese Linguistics 8, 85-106.
- McCarthy, J. (1979). On Stress and Syllabification. Linguistic Inquiry 10, 443-465.
- Selkirk, E. (1980). The Role Prosodic Categories in English Word Stress. Linguistic Inquiry 11, 563-605.
- Selkirk, E. (1982). The Syllables. Pp. 337-384 in The Structure of Phonological Representations, Part 2. Harry Van der Hult and Norval Smith, eds. Dordrecht: Foris Publications.
- Wang Li. (1957). Hanyu Shilu Xue (The Chinese Versification). Shanghai: Zhonghua Shuju.
- Yip, Moira. (1980). The Metrical Structure of Regulated Verse. Journal of Chinese Linguistics 8, 107-125.